



2.3

V90C SERIES

Swash-plate Type Axial Piston Variable Displacement Double Pump

V90C series axial piston pump is a high pressure closed circuit double pump, which can meet the application requirements of customers for harsh working conditions such as high pressure, high rotational speed and frequent impact.

Suitable for a high-pressure closed circuit

Size:	23	47	56
Rated pressure (bar):	250	420	420
Max. pressure (bar):	300	450	450

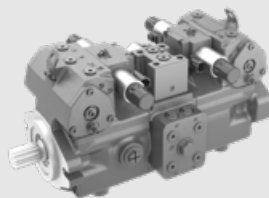

Contents

Technical Data	02-03
Type introduction	04-05
Hydraulic fluid	06
Shaft seal	07
·V90C23	08-11
·V90C47	12-30
·V90C56	31-34

Features

- Swashplate design axial piston pump for traveling machinery applications such as skid steer loader.
- Compact size, small installation space
- Various control modes such as hydraulic control, electronic control and manual control.
- Combination of DA control valve and emergency shut-off valve, etc.
- With pressure gauge oil port MA and MB.

Technical data

Size		23	47	56	
Displacement (cc/rev)		23×2	47×2	56×2	
Speed	Rated (rpm)	3300	3300	3000	
	Max. (rpm)	3600	3550	3250	
	Min. (rpm)	500	500	500	
Pressure	Rated (bar)	250	420	420	
	Max. (bar)	280	450	450	
	Min. (bar)	High-pressure side	20	25	25
		Low-pressure side	10	10	10
Charge pump displacement (cc/rev)		9.4	15/20	-	
Casting pressure	Rated (bar)	1.5	3	3	
	Max. (bar)(Short-time peak pressure)	2.5	5	5	
Oil viscosity (mm ² /s)		10~1000, Best range: 16~36			
Oil temperature (°C)		-20~95			
Oil cleanliness		ISO 4406 Class 20/18/15 or higher			
Weight (Kg)		28	56	60.3	

Technical data

Permissible input and through-drive torques					
Size		NG	23	47	56
Torque at $V_{g,max}$ and $\Delta p = 420$ bar Nm		T	183	628	748.7
Maximum input torque at drive shaft (Nm)					
ANSI B92.1	7/8 in 13T-16/32 DP	$T_{E,max}$	230		
	1 in 15T 16/32 DP	$T_{E,max}$		342	342
	1 1/4 in 14T 12/24 DP	$T_{E,max}$		602	602
Maximum through-drive torque (Nm)		$T_{D1,max}$	100	318	439
		$T_{D2,max}$	$T_{D2,perm} = 100 - T_2$	$T_{D2,perm} = 318 - T_2$	$T_{D2,perm} = 439 - T_2$

Torque distribution

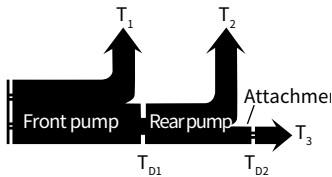

V90C	Front pump	T_1
	Rear pump	T_2
Attachment pump		T_3
Input torque		$T_E = T_1 + T_2 + T_3$
		$T_E < T_{E,max}$
Through-drive torque		T_{D1}
		T_{D2}

Type introduction

V90	C		47	E1	A	0	/	R	N	B4	3	K	B1	-	E
①	②	③	④	⑤	⑥	⑦		⑧	⑨	⑩	⑪	⑫	⑬		⑭

Axial piston unit

①	Swashplate design, variable	V90
---	-----------------------------	-----

Operating mode

②	Pump, closed circuit	C
---	----------------------	---

Variable mechanism

		23	47	56	Code
③	With servo piston	●	●	●	Blank
	Without servo piston (manual variable)		●		S

Size

④	Size	23	47	56
---	------	----	----	----

Control mode

		23	47	56	Code
⑤	Proportional control, electric U = 12 V DC	●	●	●	E1
	Proportional control, electric U = 24 V DC	●	●	●	E2
	Mechanical servo control		●	○	H1
	Hydraulic control direct operated – optimized for hydraulic control	●	●	○	H3
	Manual direct displacement control		●		H5

Remark: V90C47 when selecting without servo piston (manual variable), please choose manual direct variable control as the control method.

DA control valve

		23	47	56	Code
⑥	Without swivel DA control valve	●	●	●	Blank
	Swivel DA control valve		●	○	A

Remark: V90C47 when selecting without servo piston (manual variable), without swivel DA control valve.

Connection type

		23	47	56	Code
⑦	ANSI, port threads with O-ring seal according to ISO 11926		●	●	0
	Inch thread, port threads with ED flat washer seal according to ISO 1179	●			E

Rotation

⑧	Right hand (clockwise)	R
	Left hand (counter-clockwise)	L

Sealing material

⑨	NBR (nitrile rubber) Shaft seal in FKM (fluoroelastomer)	N
---	---	---

Type introduction

Mounting flangew and drive shaft

⑩	Mounting flange	Drive shaft	23	47	56	Code	
	SAE J744 101-2	ANSI B92.1 7/8 in 13T 16/32DP	●				B1
		ANSI B92.1 1 in 15T 16/32 DP		●			B3
		ANSI B92.1 1 1/4 in 14T 12/24 DP		●	○		B4
		ANSI B92.1 1 1/4 in 19T 16/32 DP		●	○		B5
		ANSI B92.1 1 3/8 in 21T 16/32 DP			●		B6

Working port

⑪	Oil Port Layout	S Oil Port Location	S Oil Port Standard	A/B Oil Port Standard	23	47	56	Code
	A and B on the same side face right	S located at the bottom	ISO 11926	SAE		○		4
	A and B on the opposite side, left and right	S located at the bottom	ISO 1179	ISO 1179	●			S
	A and B on the same side face left	S located at the right	ISO 11926	ISO 11926		●	●	3

Note: Default coordinates of the main pump; viewed from the shaft extension end, the control valve is located directly above the pump.

Left and right: Viewed from the shaft extension end, the right side is to the right of the observer, the left side is to the left of the observer, and the plane containing the control valve is the top.

Boost pump and rotary group configuration

⑫		23	47	56	Code
	Standard rotary group, without boost pump			●	●
Standard rotary group, built-in boost pump		●	●		F

Remark: V90C47 when selecting without servo piston (manual variable), without boost pump.

Through drive

⑬		23	47	56	Code	
	Without through drive	●	○		None	
	Flange	Splined shaft				
	SAE A J744-82-2	ANSI B92.1 5/8 in 9T 16/32 DP	●	○		A1
		ANSI B92.1 3/4 in 11T 16/32 DP		○		A2
		ANSI B92.1 7/8 in 13T 16/32 DP		○		A3
	SAE B J744-101-2	ANSI B92.1 7/8 in 13T 16/32DP		●	●	B1
ANSI B92.1 1 in 15T 16/32 DP			○		B3	

Standard / special version

⑭		23	47	56	Code
	Standard version	●	●	●	Blank
	Special version	Pilot shut-off valve, 12 V DC		●	●
Pilot shut-off valve, 24 V DC			○		F

Remark: 1. V90C47 when selecting without servo piston (manual variable), without pilot shut-off valve.

2. Swivel DA control valve , without pilot shut-off valve.

● = Available; ○ = On request

Hydraulic fluid

Viscosity and temperature of the hydraulic fluid

	Viscosity(mm ² /s)	Oil seal	Temperature	Note
Cold start	$v_{\max} \leq 1600$	NBR	$\theta_{st} \geq -40^{\circ}\text{C}$	$t \leq 3$ minutes, no load ($p \leq 50\text{bar}$), $n \leq 1000\text{rpm}$, Maximum permissible temperature difference between the rotating parts of the system and the hydraulic fluid 25°C .
		FKM	$\theta_{st} \geq -25^{\circ}\text{C}$	
Warm-up phase	$v = 1600 \cdots 400$			$t \leq 15$ minutes, $p \leq 0.7 \times p_{\text{nom}}$, $n \leq 0.5 \times n_{\text{nom}}$
Continuous operation	$v = 400 \cdots 10$	NBR	$\theta \leq +85^{\circ}\text{C}$	Measured at oil port T
		FKM	$\theta \leq +110^{\circ}\text{C}$	
	$v_{\text{opt}} = 36 \cdots 16$			Optimum operating viscosity and efficiency range
Short-term operation	$v_{\min} = 10 \cdots 7$	NBR	$\theta \leq +85^{\circ}\text{C}$	$t \leq 3$ minutes, $p \leq 0.3 \times p_{\text{nom}}$, Measured at oil port T
		FKM	$\theta \leq +110^{\circ}\text{C}$	

Selection chart

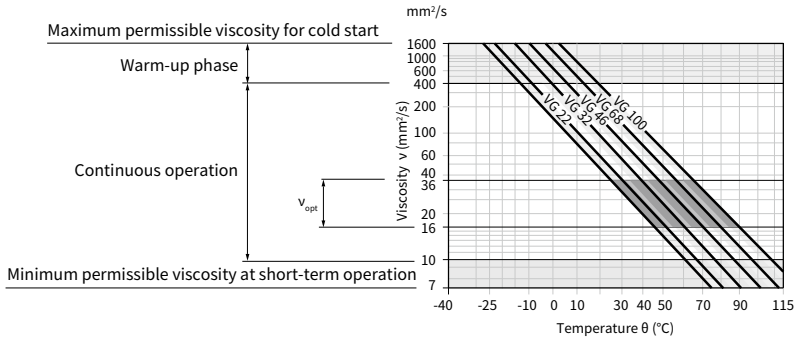

Detailed information on the selection of hydraulic fluids

To select the hydraulic fluid correctly, it is necessary to know the operating temperature in relation to the ambient temperature: in closed circuits the oil circuit temperature.

When selecting a hydraulic fluid, the operating viscosity should be in the optimum range for the operating temperature range (v_{opt} see shaded area of the selection chart). We recommend selecting a higher viscosity grade in all cases.

Example: When the operating temperature in the circuit is 60°C , in the optimum operating viscosity range (shaded area of the v_{opt}), corresponding to viscosity grades VG46 or VG68; VG68 should be selected.

Caution

The case drain temperature (influenced by pressure and speed) may be higher than the oil line temperature or tank temperature.

However, the temperature of any part of the component must not exceed 100°C .

Hydraulic fluid

Filtration of hydraulic fluid

Finer filtration improves the cleanliness of the hydraulic fluid, thereby extending the life of rotating parts. A cleanliness of at least 20/18/15 (ISO 4406) should be maintained. When the viscosity of the hydraulic fluid is less than 10mm²/s (e.g. due to high temperatures during short-term operation, a cleanliness level of at least 19/17/14 (ISO 4406) is required.

Oil seals

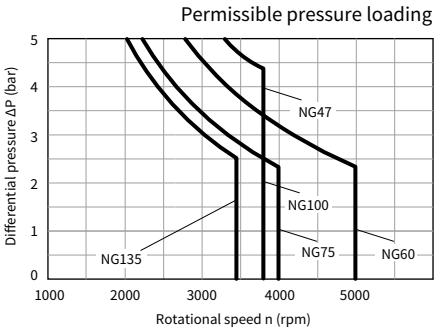

▲ Note

- When using mineral oil based hydraulic fluid, refer to the left diagram for the range of pressures used for oil seals, please contact us if other hydraulic fluids are used.
- The service life of the oil seal is affected by the rotational speed and the pressure difference between the inside and outside of the seal, in addition to the hydraulic oil and temperature.
- The pressure difference between the inside and outside of the seal must be greater than or equal to zero.

02

V90C23 Control principle

• Proportional control

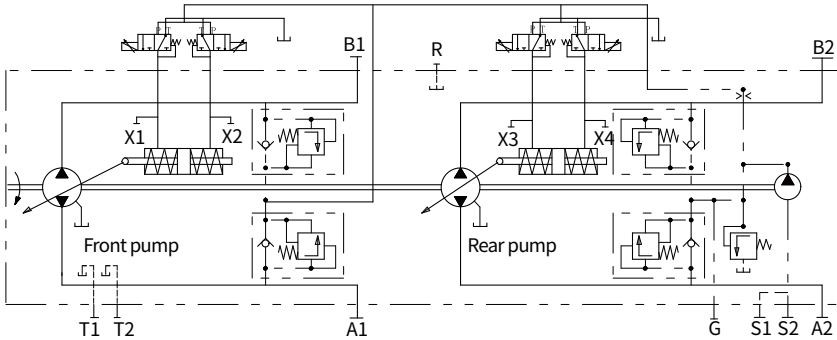

02

Control and Flow		Front pump			
		Start the electromagnet	Control pressure	High pressure	Low voltage
Rotation direction	Dextrorotation	D1	X2	A1	B1
		D2	X1	B1	A1
	Leverotation	D1	X2	B1	A1
		D2	X1	A1	B1

Control and Flow		Rear pump			
		Start the electromagnet	Control pressure	High pressure	Low voltage
Rotation direction	Dextrorotation	D3	X4	A2	B2
		D4	X3	B2	A2
	Leverotation	D3	X4	B2	A2
		D4	X3	A2	B2

Installation size

V90C23 Installation size

• Proportional control

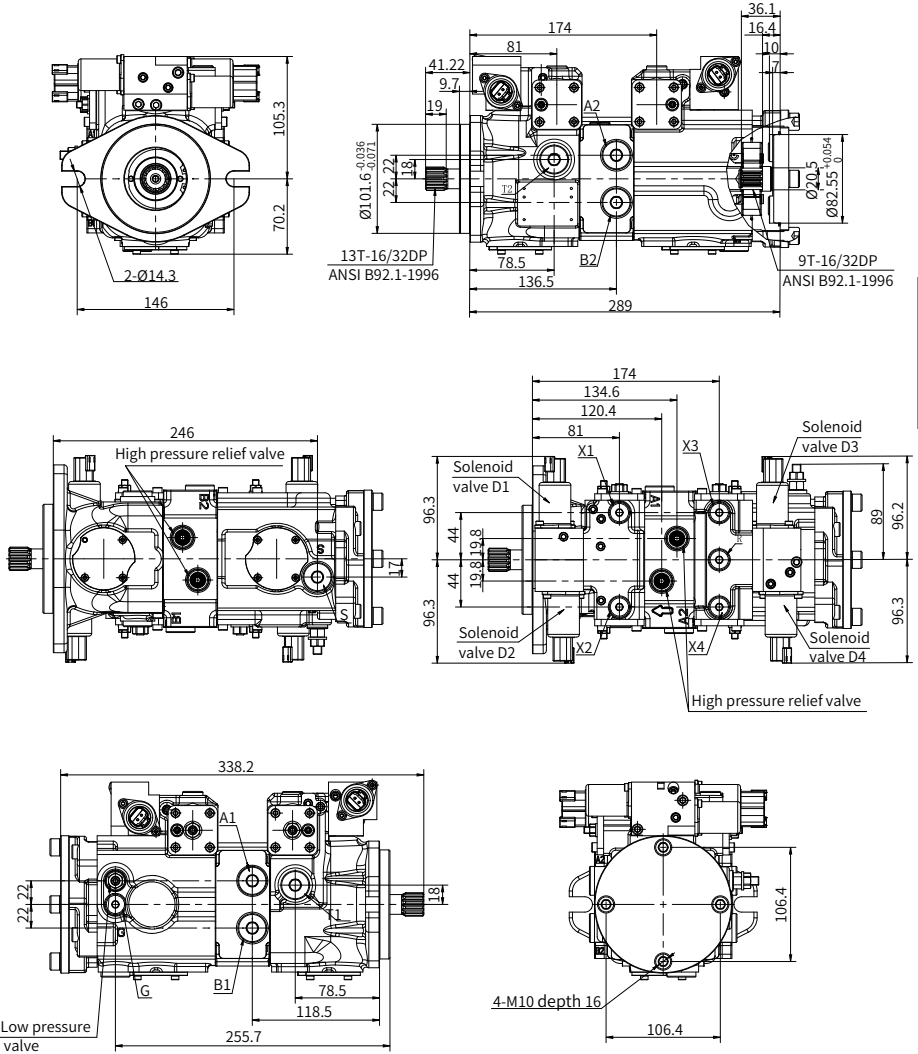

02

Installation size

•V90C23 Port details

Port	Port use	Standard	Oil Port Specification (thread depth)	Maximum pressure (bar)
A1, B1	Work lines	ISO 1179-1	G 1/2 (depth 15)	250
A2, B2	Work lines	ISO 1179-1	G 1/2 (depth 15)	250
S1, S2	Oil suction line	ISO 1179-1	G 1/2 (depth 15)	5
T1	Oil drain line	ISO 1179-1	G 1/2 (depth 15)	3
T2	Oil drain line	ISO 1179-1	G 1/2 (depth 15)	3
R	Exhaust port	ISO 1179-1	G 1/4 (depth 12.5)	3
X1, X2, X3, X4	Control cavity pressure	ISO 1179-1	G 1/4 (depth 12.5)	40
G	Top-up pressure	ISO 1179-1	G 1/4 (depth 12.5)	40

Installation size

•V90C23 shaft extension type

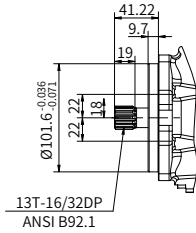

"B1" type spline shaft

ANSI B92.1 1 1/4 14T
12/24DP

•V90C23 through shaft drive

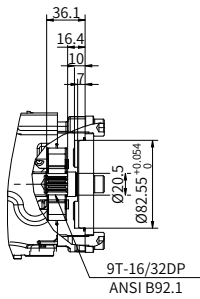

"B1" type through drive

V90C47 Control principle

· Hydraulic control direct operated (With DA control)

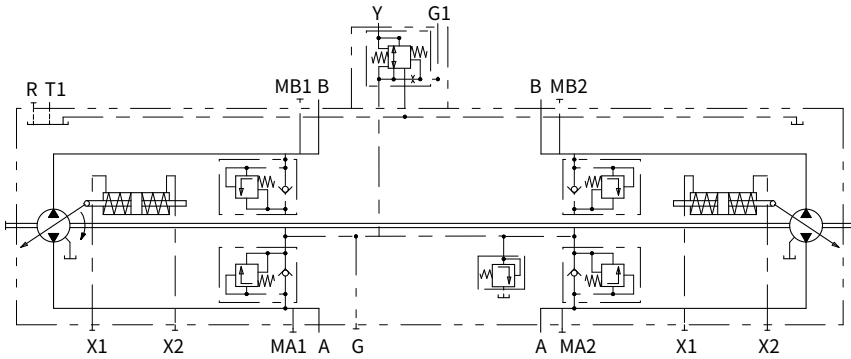

02

Direction of rotation	Clockwise				Counter-clockwise			
	1st pump		2nd pump		1st pump		2nd pump	
Control pressure	X1	X2	X3	X4	X1	X2	X3	X4
Flow direction	A to B	B to A	B to A	A to B	B to A	A to B	A to B	B to A
Working pressure	MB1	MA1	MA2	MB2	MA1	MB1	MB2	MA2

Installation size

V90C47 Installation size

Hydraulic control direct operated (With DA control)

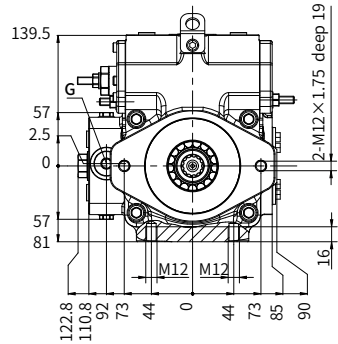
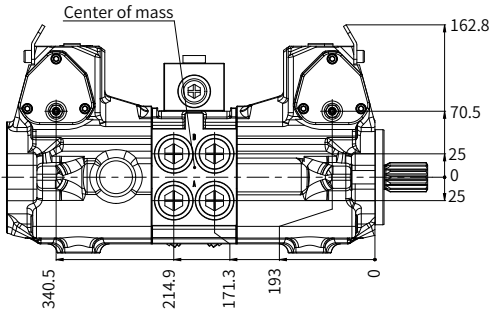
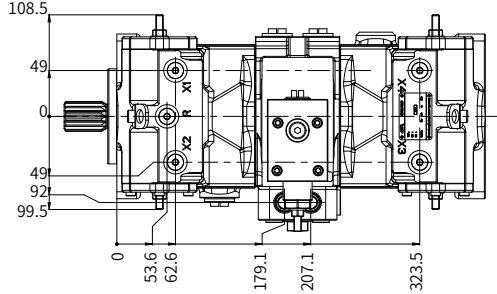
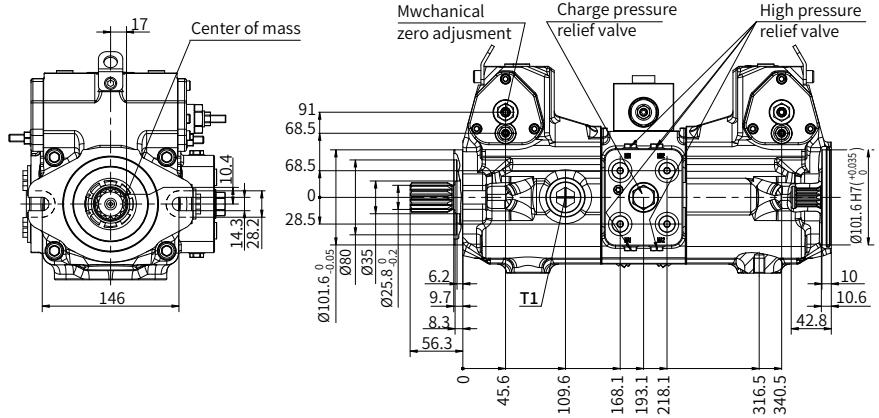

02

Installation size

V90C47 Port details

· Hydraulic control direct operated (With DA control)

Port	Port Name	Standard	Oil Port Specification (thread depth)
A, B	Working port	ISO 11926	1 1/16-12UN-2B (depth 20)
T1	Drain port	ISO 11926	1 1/16-12UN-2B (depth 20)
R	Air bleed port	ISO 11926	9/16-18UNF-2B (depth 13)
X1, X2 X3, X4	Control pressure port	ISO 11926	9/16-18UNF-2B (depth 13)
Y	Pilot pressure port inlet	ISO 11926	9/16-18UNF-2B (depth 13)
G1	Boost pressure port inlet	ISO 11926	3/4-16UNF-2B (depth 15)
G	Boost pressure port inlet	ISO 11926	3/4-16UNF-2B (depth 15)

V90C47 Control principle

• Mechanical servo control

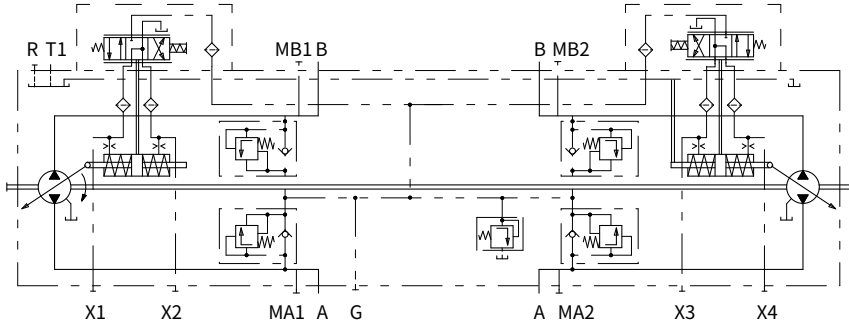

Direction of rotation	Clockwise				Counter-clockwise			
	1st pump		2nd pump		1st pump		2nd pump	
Control pressure	X1	X2	X3	X4	X1	X2	X3	X4
Flow direction	A to B	B to A	B to A	A to B	B to A	A to B	A to B	B to A
Working pressure	MB1	MA1	MA2	MB2	MA1	MB1	MB2	MA2

02

Installation size

V90C47 Installation size

· Mechanical servo control

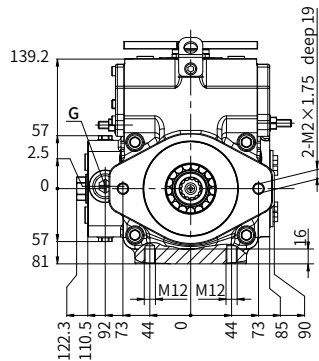
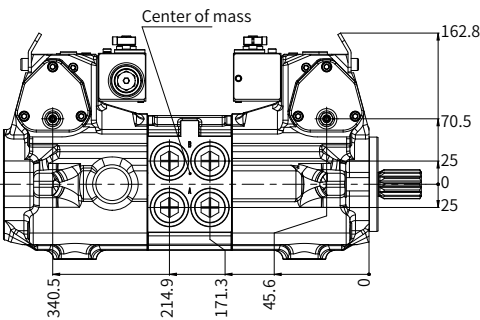
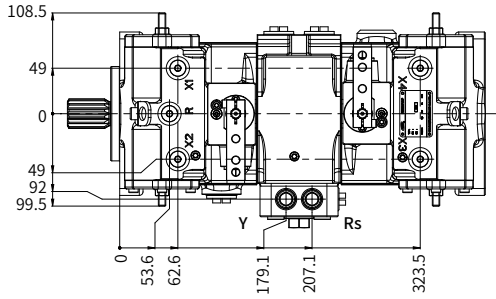
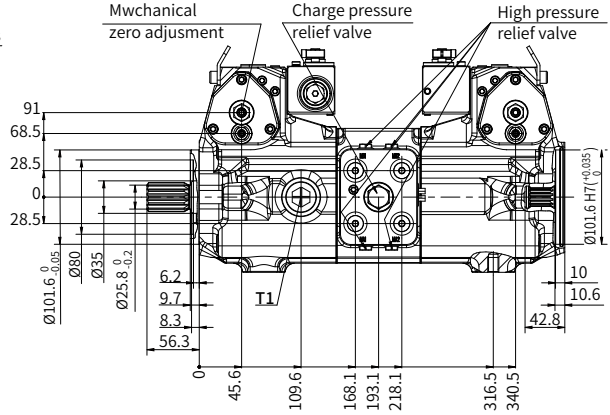
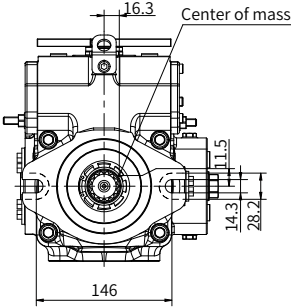

02

Installation size

V90C47 Port details

• Mechanical servo control

Port	Port Name	Standard	Oil Port Specification (thread depth)
A, B	Working port	ISO 11926	1 1/16-12UN-2B (depth 20)
T1	Drain port	ISO 11926	1 1/16-12UN-2B (depth 20)
R	Air bleed port	ISO 11926	9/16-18UNF-2B (depth 13)
X1, X2 X3, X4	Control pressure port	ISO 11926	9/16-18UNF-2B (depth 13)
G	Boost pressure port inlet	ISO 11926	3/4-16UNF-2B (depth 15)
MA1, MB1 MA2, MB2	Pressure port	ISO 11926	9/16-18UNF-2B (depth 13)

V90C47 Control principle

• Proportional control

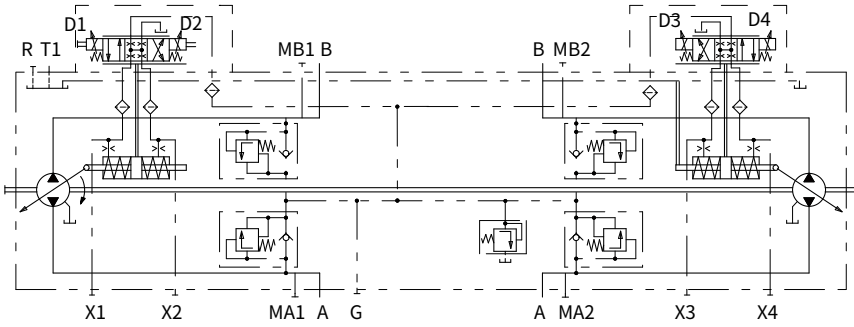

02

Direction of rotation	Clockwise				Counter-clockwise			
	1st pump		2nd pump		1st pump		2nd pump	
Start the electromagnet	D1	D2	D3	D4	D1	D2	D3	D4
Control pressure	X1	X2	X3	X4	X1	X2	X3	X4
Flow direction	A to B	B to A	B to A	A to B	B to A	A to B	A to B	B to A
Working pressure	MB1	MA1	MA2	MB2	MA1	MB1	MB2	MA2

Installation size

V90C47 Installation size

• Proportional control

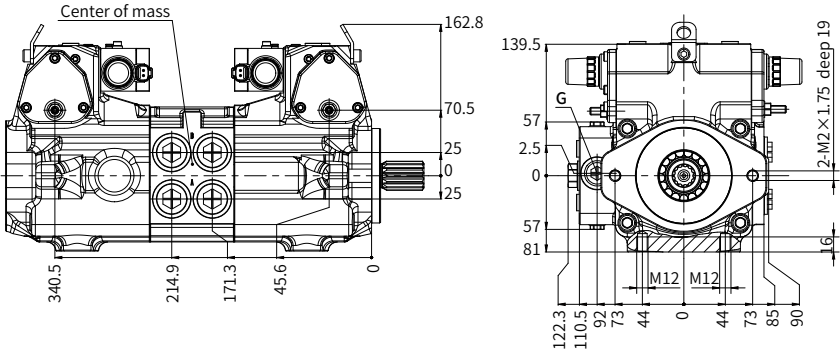
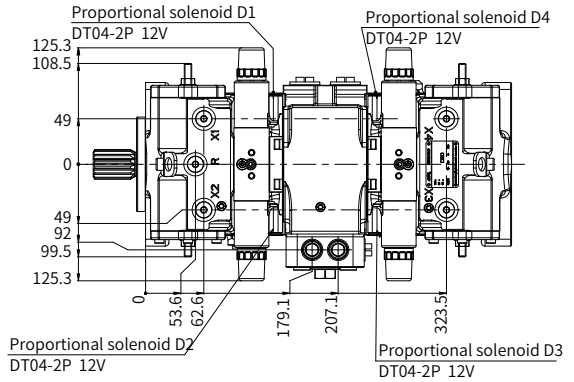
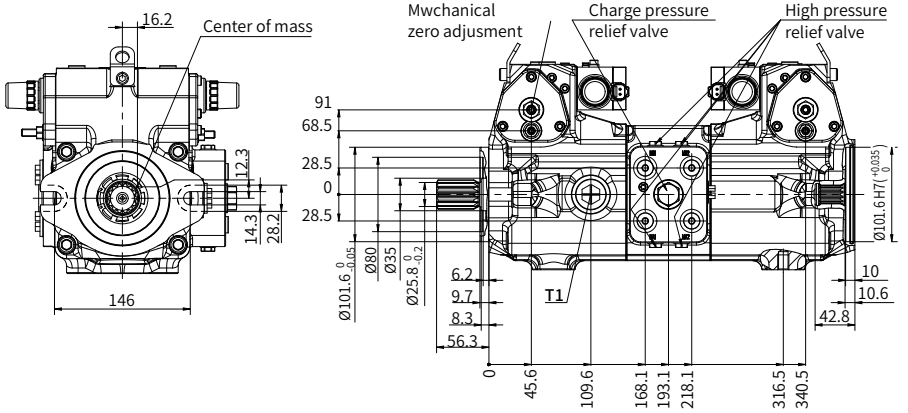

Installation size

V90C47 Port details

· Proportional control

Port	Port Name	Standard	Oil Port Specification (thread depth)
A, B	Working port	ISO 11926	1 1/16-12UN-2B (depth 20)
T1	Drain port	ISO 11926	1 1/16-12UN-2B (depth 20)
R	Air bleed port	ISO 11926	9/16-18UNF-2B (depth 13)
X1, X2 X3, X4	Control pressure port	ISO 11926	9/16-18UNF-2B (depth 13)
G	Boost pressure port inlet	ISO 11926	3/4-16UNF-2B (depth 15)
MA1, MB1 MA2, MB2	Pressure port	ISO 11926	9/16-18UNF-2B (depth 13)

V90C47 Control principle

· Proportional control (with emergency brake valve)

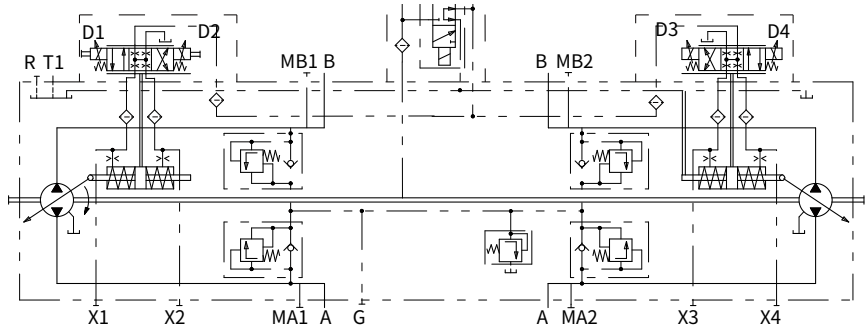

Direction of rotation	Clockwise				Counter-clockwise			
	1st pump		2nd pump		1st pump		2nd pump	
Start the electromagnet	D1	D2	D3	D4	D1	D2	D3	D4
Control pressure	X1	X2	X3	X4	X1	X2	X3	X4
Flow direction	A to B	B to A	B to A	A to B	B to A	A to B	A to B	B to A
Working pressure	MB1	MA1	MA2	MB2	MA1	MB1	MB2	MA2

Installation size

V90C47 Installation size

·Proportional control (with emergency brake valve)

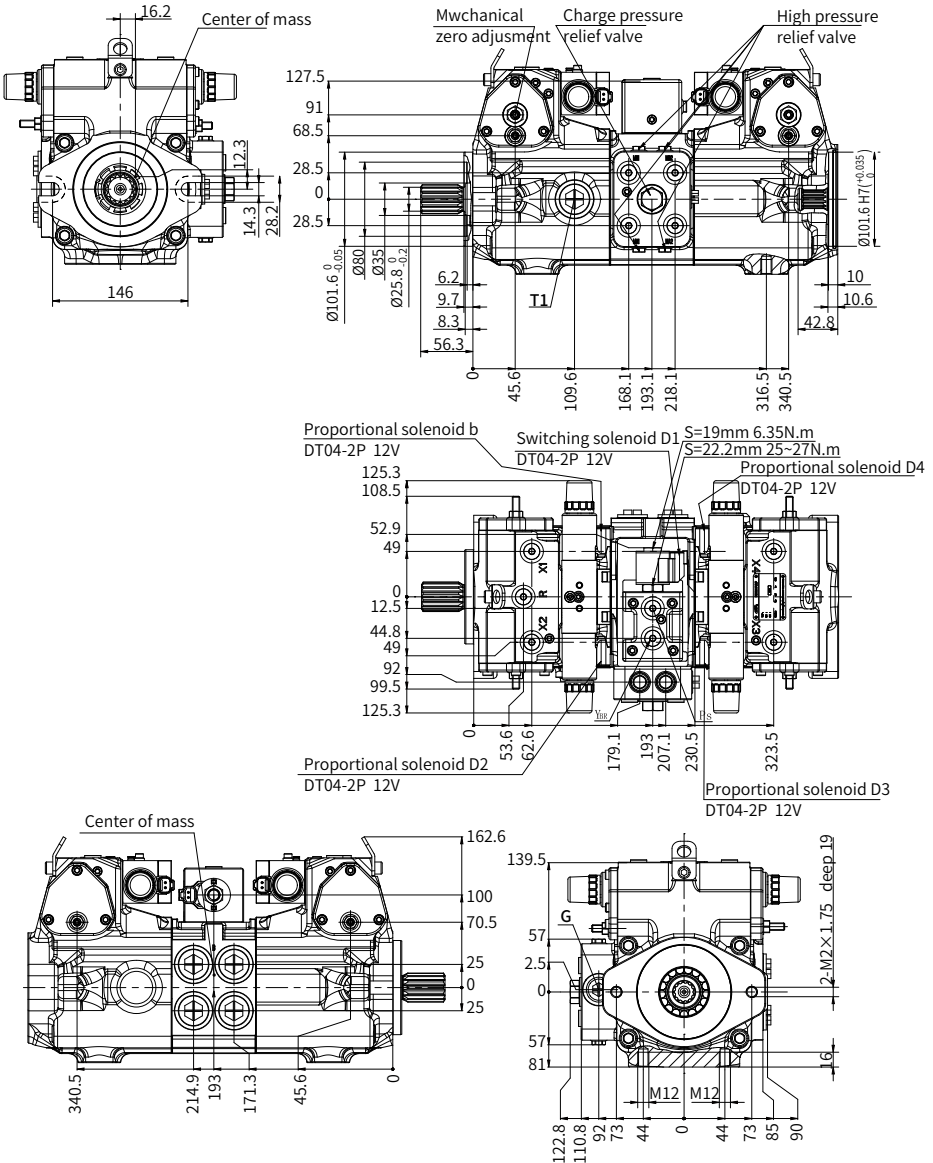

Installation size

V90C47 Port details

• Proportional control (with emergency brake valve)

Port	Port Name	Standard	Oil Port Specification (thread depth)
A, B	Working port	ISO 11926	1 1/16-12UN-2B (depth 20)
T1	Drain port	ISO 11926	1 1/16-12UN-2B (depth 20)
R	Air bleed port	ISO 11926	9/16-18UNF-2B (depth 13)
X1, X2 X3, X4	Control pressure port	ISO 11926	9/16-18UNF-2B (depth 13)
G	Boost pressure port inlet	ISO 11926	3/4-16UNF-2B (depth 15)
Y _{BR}	Pressure port	ISO 11926	9/16-18UNF-2B (depth 13)
P _s	Pressure port	ISO 11926	9/16-18UNF-2B (depth 13)
MA1, MB1 MA2, MB2	Pressure port	ISO 11926	9/16-18UNF-2B (depth 13)

V90C47 Control principle

• Proportional control (with oil replenishment pump)

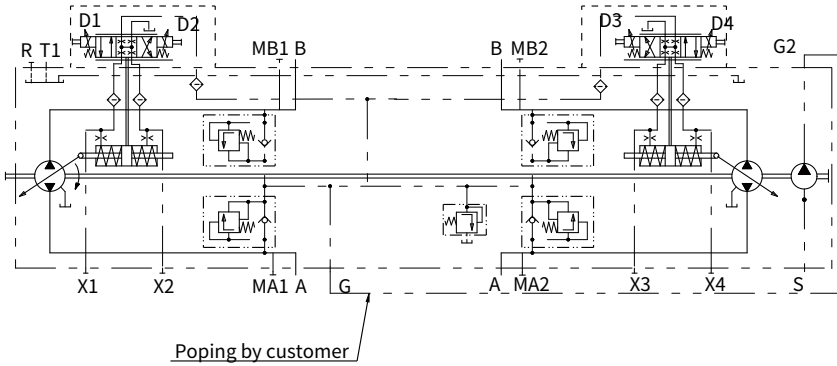

02

Direction of rotation	Clockwise				Counter-clockwise			
	1st pump		2nd pump		1st pump		2nd pump	
Start the electromagnet	D1	D2	D3	D4	D1	D2	D3	D4
Control pressure	X1	X2	X3	X4	X1	X2	X3	X4
Flow direction	A to B	B to A	B to A	A to B	B to A	A to B	A to B	B to A
Working pressure	MB1	MA1	MA2	MB2	MA1	MB1	MB2	MA2

Installation size

V90C47 Installation size

· Proportional control (with oil replenishment pump)

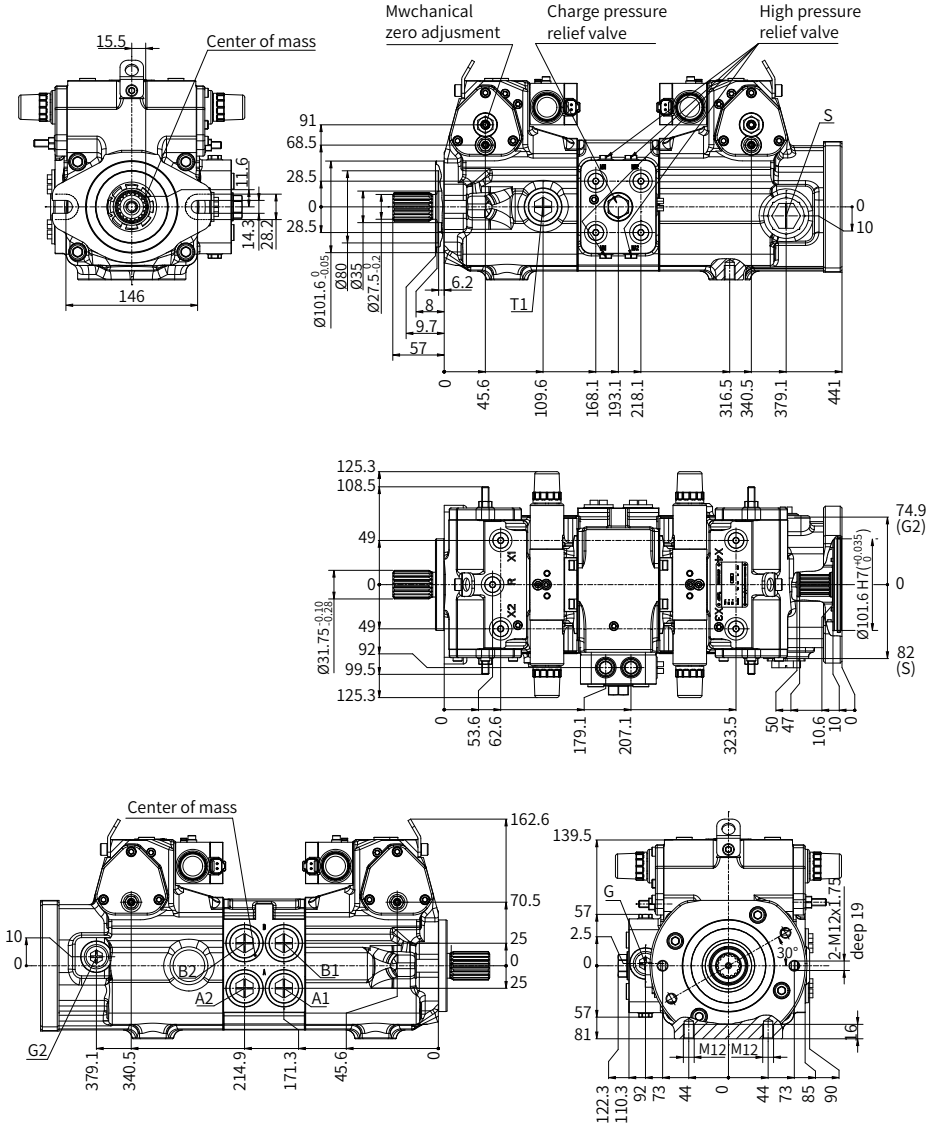

Installation size

V90C47 Port details

· Proportional control (with oil replenishment pump)

Port	Port Name	Standard	Oil Port Specification (thread depth)
A, B	Working port	ISO 11926	1 1/16-12UN-2B (depth 20)
T1	Drain port	ISO 11926	1 1/16-12UN-2B (depth 20)
R	Air bleed port	ISO 11926	9/16-18UNF-2B (depth 13)
X1, X2 X3, X4	Control pressure port	ISO 11926	9/16-18UNF-2B (depth 13)
G	Boost pressure port inlet	ISO 11926	3/4-16UNF-2B (depth 15)
Y _{BR}	Pressure port	ISO 11926	9/16-18UNF-2B (depth 13)
P _s	Pressure port	ISO 11926	9/16-18UNF-2B (depth 13)
MA1, MB1 MA2, MB2	Pressure port	ISO 11926	9/16-18UNF-2B (depth 13)

V90CS47 Control principle

• Manual direct displacement control

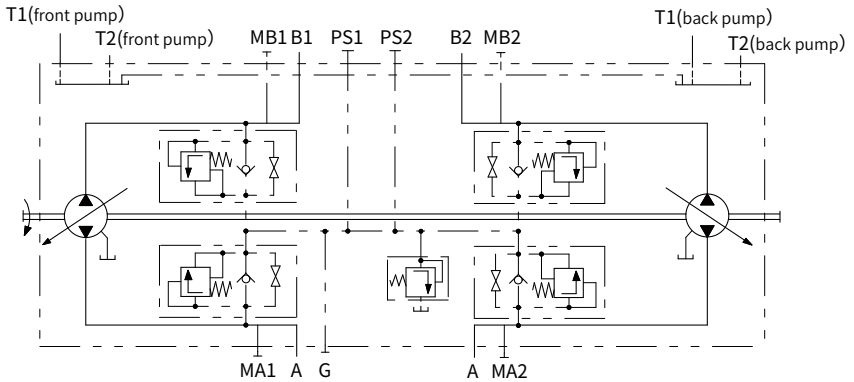

Direction of rotation	Clockwise			
	1st pump		2nd pump	
Direction of tie rod	Clockwise	Counter-clockwise	Clockwise	Counter-clockwise
Flow direction	A to B	B to A	B to A	A to B
Working pressure	MB1	MA1	MA2	MB2

Direction of rotation	Counter-clockwise			
	1st pump		2nd pump	
Direction of tie rod	Clockwise	Counter-clockwise	Clockwise	Counter-clockwise
Flow direction	B to A	A to B	A to B	B to A
Working pressure	MA1	MB1	MB2	MA2

02

Installation size

V90CS47 Port details

· Manual direct displacement control

Port	Port Name	Standard	Oil Port Specification (thread depth)
A, B	Working port	ISO 11926	1 1/16-12UN-2B (depth 20)
T1	Drain port	ISO 11926	1 1/16-12UN-2B (depth 20)
G	Boost pressure port inlet	ISO 11926	3/4-16UNF-2B (depth 15)
MA1, MB1 MA2, MB2	Pressure port	ISO 11926	9/16-18UNF-2B (depth 13)
PS1、PS2	Boost pressure port	ISO 11926	9/16-18UNF-2B (depth 13)

Installation size

·V90C(S)47 shaft extension type

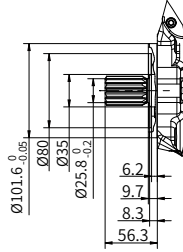
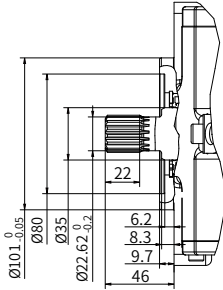

"B3" type spline shaft
ANSI B92.1
1 in 15T 16/32 DP

"B4" type spline shaft
ANSI B92.1
1 1/4 14T 12/24DP

·V90C(S)47 through shaft drive

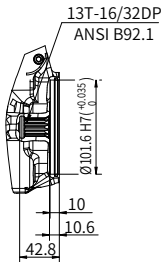

"B1" type through drive

V90C56 Control principle

• Proportional control (with emergency brake valve)

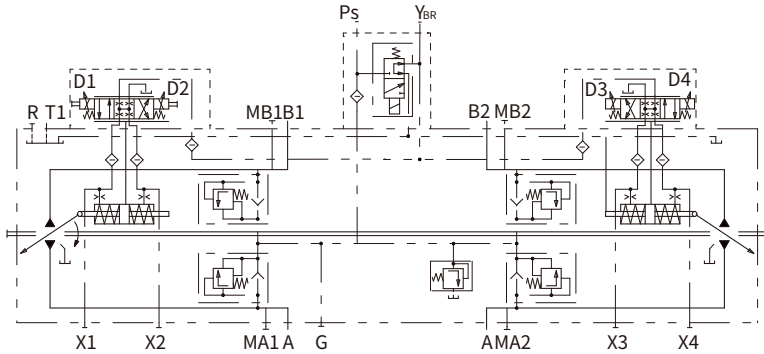

Direction of rotation	Clockwise				Counter-clockwise			
	1st pump		2nd pump		1st pump		2nd pump	
Start the electromagnet	D1	D2	D3	D4	D1	D2	D3	D4
Control pressure	X1	X2	X3	X4	X1	X2	X3	X4
Flow direction	A1 to B1	B1 to A1	B2 to A2	A2 to B2	B1 to A1	A2 to B2	A2 to B2	B2 to A2
Working pressure	MB1	MA1	MA2	MB2	MA1	MB1	MB2	MA2

Installation size

V90C56 Installation size

• Proportional control (with emergency brake valve)

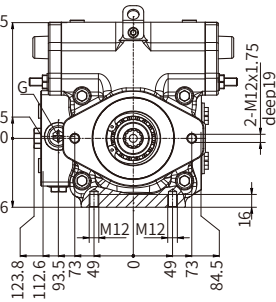
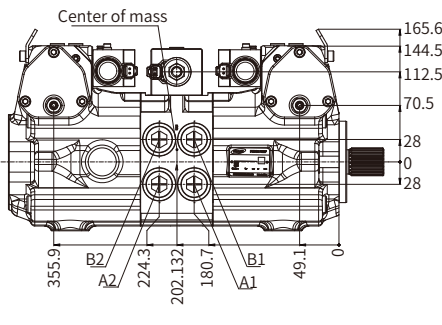
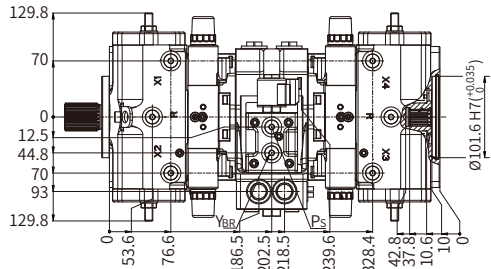
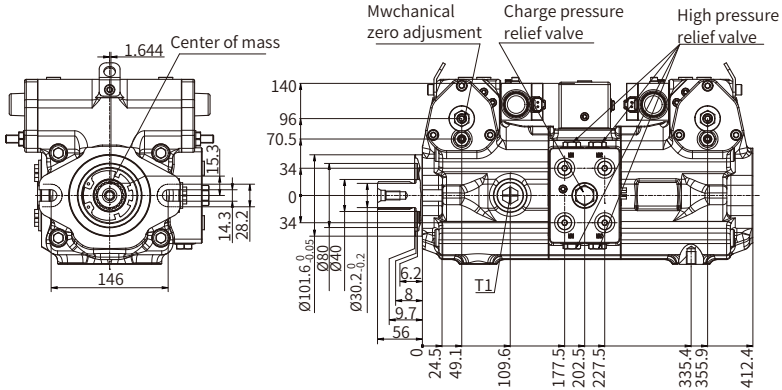

Installation size

V90C56 Port details

· Proportional control (with emergency brake valve)

Port	Port Name	Standard	Oil Port Specification (thread depth)
A, B	Working port	ISO 11926	1 1/16-12UN-2B (depth 20)
T1	Drain port	ISO 11926	1 1/16-12UN-2B (depth 20)
R	Air bleed port	ISO 11926	9/16-18UNF-2B (depth 13)
X1, X2 X3, X4	Control pressure port	ISO 11926	9/16-18UNF-2B (depth 13)
G	Boost pressure port inlet	ISO 11926	3/4-16UNF-2B (depth 15)
Y _{BR}	Pressure port	ISO 11926	9/16-18UNF-2B (depth 13)
P _s	Pressure port	ISO 11926	9/16-18UNF-2B (depth 13)
MA1, MB1 MA2, MB2	Pressure port	ISO 11926	9/16-18UNF-2B (depth 13)

Installation size

·V90C56 shaft extension type

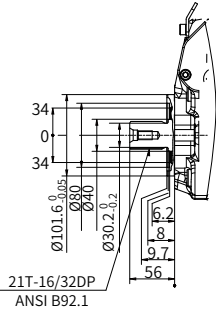

"B6" type spline shaft

ANSI B92.1

1 3/8 21T 16/32 DP

·V90C56 through shaft drive

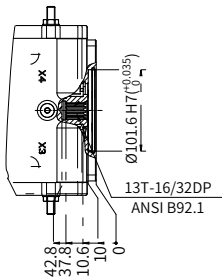

"B1" type through drive



© Hengli Hydraulics retains the copyright, trade mark rights and other intellectual property rights in all contents of this brochure. No part of this brochure may be reproduced, edited, duplicated or electronically transmitted in any way without authorisation. As products are constantly being optimised and innovated, we do not warrant that all information is completely accurate, complete or up-to-date at any point in time.