

2.4



HVA series

Orbital hydraulic motor

HVA series orbital hydraulic motor is a new generation of low-speed high-torque hydraulic motor, after the optimization of the internal structure of the motor, the motor has a more compact structure, higher efficiency, higher operating pressure.

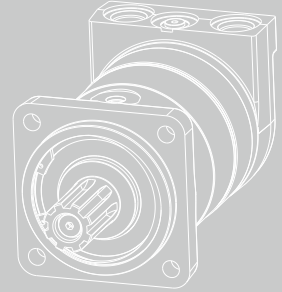

Contents

Overview	02
Advantages	02
Standard structure	02
Specification	03
Ordering information	04
Displacement performance	05-06
Installation size	07
Length and weight	07
Shaft end dimensions	08
Allowable shaft load/bearing curve	09
Hydraulic diagram	09
Rotation direction	10



Overview

HVA series cycloidal hydraulic motor is a new generation of low-speed high-torque hydraulic motor, after the optimization of the internal structure of the motor, the motor has a more compact structure, higher efficiency, higher operating pressure. The HVA series cycloidal hydraulic motors are mainly used in closed circuits.

Advantages

- Compact structure.
- High output torque.
- High motor efficiency.
- Smooth operation.
- A variety of mounting sizes, output shaft sizes are available.
- It has passed more than 400 hours of high temperature and high pressure durability test, with long service life and high pressure resistance.
- Can be built-in flushing valve or one-way valve.

Standard structure

HVA Orbital hydraulic motor

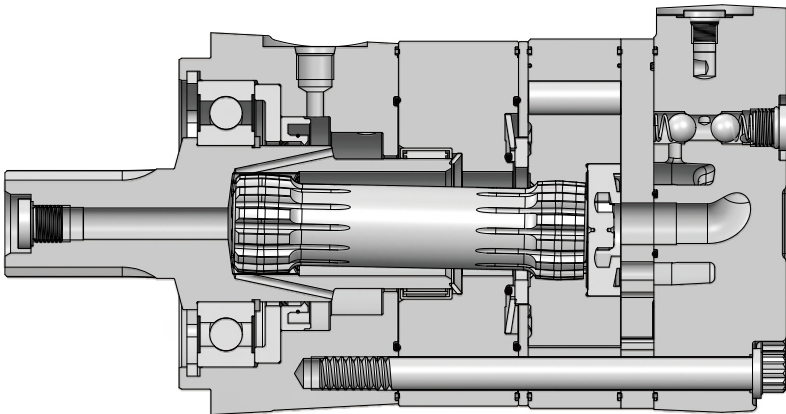

P-0103

Specification

Type		HVA			
Displacement(cm ³ /rev.)		325	400	505	570
Max.speed(rpm)	Continuous	341	280	213	186
	Intermittent	394	330	240	212
Max.torque(Nm)	Continuous	1600	1600	1600	1600
	Intermittent	2000	2000	2000	2000
Max.differential pressure(bar)	Continuous	310	255	254	223
	Intermittent	345	320	305	268
Max.flow(L/min)	Continuous	114	114	114	114
	Intermittent	132	132	132	132
Weight(kg)		25.2	25.9	26.9	27.5

T-0097

- Intermittent working condition: The working time should be less than 6 seconds per minute under the intermittent working condition.
- It is not recommended for the motor to work at simultaneous maximum torque and maximum speed.
- The filtration standard of ISO 4406 cleaning standard 20/18/15 is recommended.
- High quality anti-wear hydraulic fluids are recommended.
- When the temperature is 50° C, the minimum viscosity of the oil is recommended to be 20mm²/s.
- The recommended maximum operating temperature is 82°C .
- To assure best motor life, run motor 10-15 minutes in low speed high torque mode at approximately 50% of continuous pressure and 50% of continuous flow.

Ordering information

HVA	400	F32	R2	A	N	A
①	②	③	④	⑤	⑥	⑦

Orbital Hydraulic Series

①	Orbital Hydraulic Motor	HVA
---	-------------------------	-----

Type

②	Type	325	400	505	570
---	------	-----	-----	-----	-----

Mount, Port

③	4×Ø14.3 Square mount, pilot Ø127×12.2, port 1-1/16-12UN, drain port 9/16-18UNF	F32
---	--	-----

Output Shaft

④	Ø42 shaft, spline 8×7	R2
	Ø38.1 spline shaft 17T 12/24, center hole 3/8-16UNC	R3

Rotation Direction

⑤	CW	A
	CCW	R

Paint Option

⑥	No Paint	N
	Black	B
	Hengli blue	C

Special Features

⑦	Standard	A
	Free running	F
	High temperature	V
	Low temperature	S

T - 0107

Note: When using the order information, the user can select the motor series, displacement, installation flange, port, shaft and other information. If the selected specification is not in the table or has special requirements, please contact us.

Displacement performance

		Pressure(bar)									Max.Cont	Max.Inter
		15	35	70	105	140	170	205	240	275	310	345
325		325cm ³ /rev.										
		Torque(N·m), Speed(rpm)										
Flow (L/min)	15	58	145	301	456	606	751	911	1059	1247	1470	1498
		45	45	44	43	42	42	41	40	38	36	34
	30	66	148	306	459	618	771	924	1063	1260	1494	1506
		92	91	89	87	84	83	82	81	77	72	69
	45	69	156	306	460	608	764	897	1035	1177	1307	1434
		134	130	128	126	123	123	122	120	119	119	117
	61	77	156	289	442	595	750	907	1032	1172	1342	1401
	178	175	172	169	164	161	158	158	157	151	151	
76	74	147	282	435	585	745	903	1028	1166	1334		
	225	221	217	213	207	204	200	200	199	193		
95	74	149	279	430	575	743	876	1030	1169			
	288	283	279	276	273	265	260	258	256			
Max.Cont	114		151	278	428	578	736	901	1032	1171		
			341	336	332	329	319	313	310	309		
Max.Inter	132		147	375	425	573	730	896	1029			
			394	388	385	380	369	361	359			

Overall Efficiency: 70-100% 40-69% 0-39%

T-0114

		Pressure(bar)									Max.Cont	Max.Inter
		15	35	70	105	140	170	205	240	275	310	345
400		400cm ³ /rev.										
		Torque(N·m), Speed(rpm)										
Flow (L/min)	15	67	169	364	551	723	837	1053	1197	1444	1618	1761
		37	31	27	30	28	27	25	27	31	29	28
	30	67	176	371	564	753	914	1099	1280	1440	1628	1783
		69	69	65	64	64	63	62	61	63	60	56
	45	64	173	371	566	756	918	1100	1275	1498	1649	
		104	104	101	99	99	96	95	96	96	96	
	61	56	163	366	562	752	913	1097	1272	1499	1641	
	149	143	139	139	137	128	133	130	127	123		
76	44	153	357	553	743	898	1084	1264	1507			
	183	180	172	175	172	172	168	165	161			
95	23	132	340	538	732	886	1071	1256				
	234	229	216	215	215	212	209	207				
Max.Cont	114		157	357	547	723	917	1130	1268			
			280	274	271	268	260	255	253			
Max.Inter	132		151	345	543	717	915	1098	1262			
			330	316	312	308	299	296	292			

Overall Efficiency: 70-100% 40-69% 0-39%

T-0101

Displacement performance

		Pressure(bar)									Max.Cont	Max.Inter
		15	35	70	105	140	170	205	240	275	310	
505												
505cm ³ /rev.												
		Torque(N·m), Speed(rpm)										
Flow (L/min)	15	110	225	265	696	931	1137	1360	1543	1826	2038	
		28	28	27	27	26	26	25	25	23	22	
	30	119	238	492	732	985	1216	1474	1622	1860		
		59	58	57	55	54	54	53	52	48		
	45	113	238	487	742	990	1222	1487	1695	1892		
		81	77	75	74	74	73	71	71	70		
	61	94	230	476	724	969	1210	1477	1654			
	108	103	101	99	99	99	98	98				
76	77	205	462	708	948	1200	1474	1699				
	139	136	133	129	128	125	124	119				
95	49	193	447	693	935	1191	1451	1725				
	180	177	173	168	167	163	161	155				
Max.Cont	114		167	420	674	916	1169	1423	1603			
			213	209	206	201	197	195	189			
Max.Inter	132			389	646	885	1142	1382				
				240	237	230	227	225				

Overall Efficiency: 70-100% 40-69% 0-39%

T-0115

		Pressure(bar)							Max.Cont	Max.Inter
		15	35	70	105	140	170	205	225	260
570										
570cm ³ /rev.										
		Torque(N·m), Speed(rpm)								
Flow (L/min)	15	102	255	527	793	1055	1286	1513	1654	1886
		24	21	21	21	20	20	19	18	18
	30	141	274	570	856	1144	1427	1702	1852	2003
		49	46	46	46	45	45	44	44	44
	45	132	267	566	870	1150	1433	1713	1889	2157
		69	67	66	64	64	63	62	62	62
	61	93	252	556	849	1135	1420	1716	1873	1466
	92	90	89	87	87	86	86	85	126	
76	67	222	533	829	1114	1401	1687	1862	1452	
	119	118	117	113	112	110	109	105	158	
95	34	201	499	790	1087	1383	1653	1675		
	158	155	153	151	148	144	143	135		
Max.Cont	114		159	449	750	1043	1339	1614	1671	
			186	184	183	179	175	177	161	
Max.Inter	132			396	694	984	1284	1098	1185	
				212	210	207	201	296	292	

Overall Efficiency: 70-100% 40-69% 0-39%

T-0116

Installation size

HVA series orbital hydraulic motor

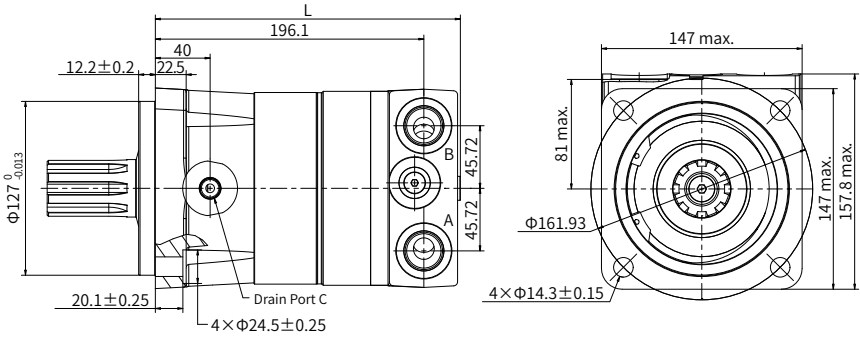

P-0104

F32 Port A, B: 1-1/16-12UN; Drain Port C: 9/16-18UNF

Length and weight

Displacement(cm ³ /rev.)	L mm
325	216.0
400	222.7
505	232.0
570	237.8

T-0100

Note: Dimensions L are the length from the flange mounting surface to the rear end of the motor, and the tolerance is ±1.2mm.

Shaft end dimensions

R2 Ø42mm shaft, spline 8x7

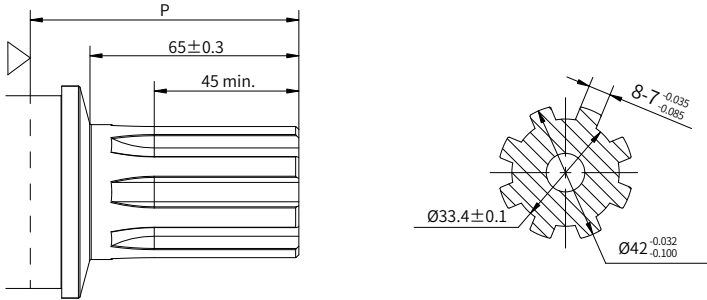

P-0107

R3 Ø38.1 spline shaft 17T 12/24, center hole 3/8-16UNC

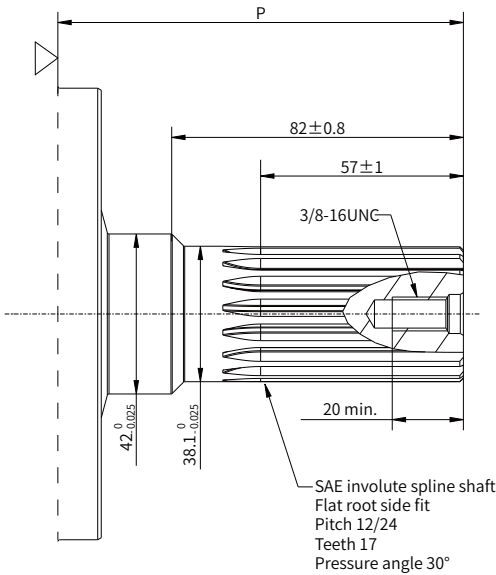

P-0309

Shaft depth	P mm
R2	79.1
R3	114

Note: Dimension P is the overall distance from the flange mounting surface to the end of the shaft, and the tolerance is ± 1.2 mm.

Allowable shaft load/bearing curve

As shown in the figure, when the axial load is 0, the radial allowable load of the output shaft is related to the distance from the flange mounting surface to the load action point.

The solid line shows the allowable radial load of the bearing. It is based on L_{10} bearing life 2000 hrs at 100 RPM with rated output torque.

Any shaft load exceeding the values quoted in the curve will involve a risk of failure.

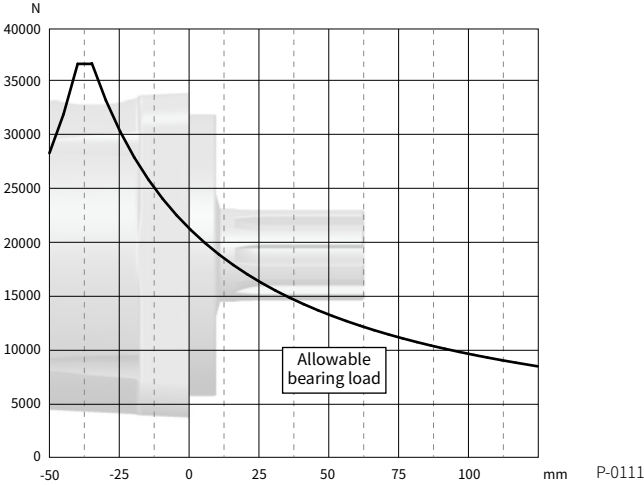

Schematic diagram of the functional module

· Schematic diagram with check valve

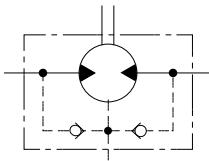

P-0010

· Schematic diagram with flushometer

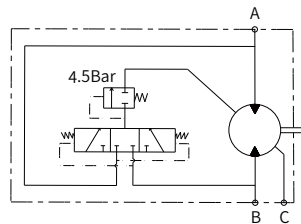

P-0108

Rotation direction: CW

When facing the motor shaft extension direction, port A is high pressure oil, the output shaft rotates CW; Otherwise, it rotates CCW.

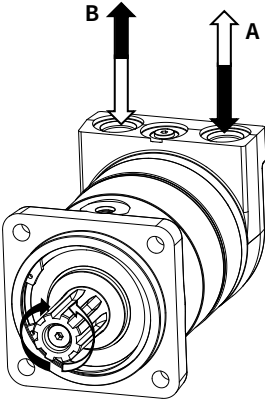

P-0109