

2.2

Hengli®

HSP series

Orbital hydraulic motor

The HSP motor is a product with improved reliability at the same pressure flow rate as the HSD, designed for all kinds of tough applications with small installation space. Stronger internal spline design, patented axial clearance adjustment design and enhanced bearing design improves reliability of HSP series motor.

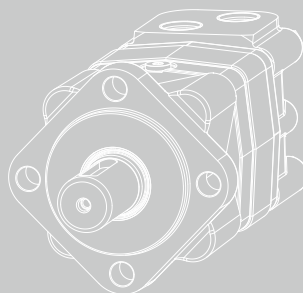

Contents

Overview	02
Advantages	02
Standard structure	03
Specification	04
Ordering information	05-06
Displacement performance	07-11
Installation size	12-14
Length and weight	15
Speed sensor	15-16
Shaft end dimensions	17-20
Allowable shaft load/bearing curve	20-21
Hydraulic diagram	21
Rotation direction	21



Overview

The HSP motor is a product with improved reliability at the same pressure flow rate as the HSD, designed for all kinds of tough applications with small installation space. Stronger internal spline design, patented axial clearance adjustment design and enhanced bearing design improves reliability of HSP series motor. Designed for some classic tough applications like Cane-harvester, Auger rigs, Mobile crusher and Wheel loader etc.

Advantages

- Using tapered roller bearing structure, can support larger axial and radial load.
- HengLi's patented axial clearance adjustment design can improve the wearing of drive.
- The motor's improved spline strength, shaft strength and bearing side load capability make sure high reliability comparing competitors, also passed endurance test with more than 1000Nm torque to prove the robust design.
- Compared with market competitors, the HSP motor delivers superior drive, seal, bearing life and full displacements from 80cc to 500cc, which means that our customers do not have to sacrifice reliability in a cost-effective solution.
- Optional relief valve, speed sensor.

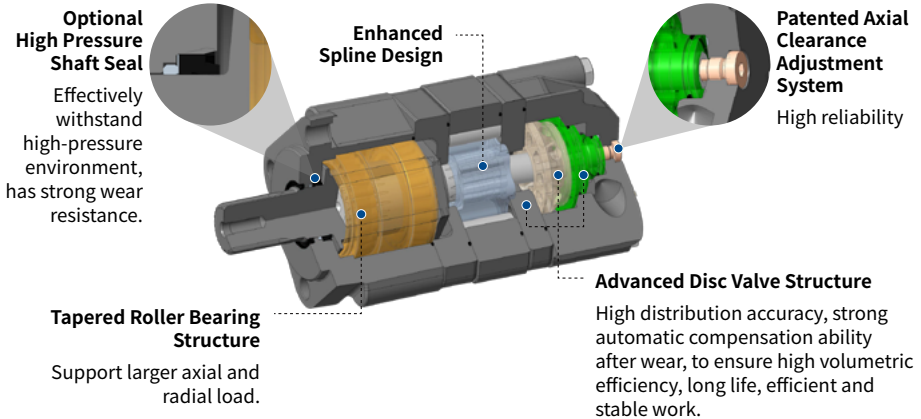

Standard structure

HSP Orbital hydraulic motor

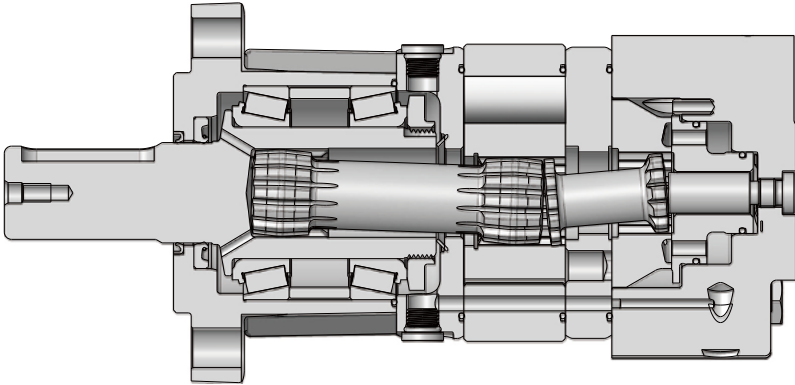

02

P-0137

Specification

Type		80	100	125	160	200	230	250	315	400	500
Displacement (cm ³ /rev.)		80.2	99.6	124.9	159.2	199.4	232.1	249.3	314.0	391.9	488.3
Max.speed (rpm)	Continuous	773	739	592	465	372	318	298	236	188	153
	Intermittent	982	892	714	562	447	385	359	284	229	187
Max.torque (N·m)	Continuous	241	297	370	473	610	658	760	874	897	847
	Intermittent	316	390	485	580	727	812	855	987	1056	986
Max.output (kW)	Continuous	15.5	18.0	18.0	16.5	16.5	13.8	14.5	15.0	11.0	9
	Intermittent	19.5	22.5	22.5	23.0	22.0	17.2	18.0	17.0	12.5	10.5
Max. differential pressure (bar)	Continuous	225	225	225	225	225	225	225	225	175	120
	Intermittent	275	275	275	260	250	250	250	240	190	140
	Peak	295	295	295	280	270	270	270	260	210	160
Max.flow (L/min)	Continuous	65	75	75	75	75	75	75	75	75	75
	Intermittent	80	90	90	90	90	90	90	90	90	90
Max.no-load starting pressure (bar)		12	10	10	8	8	8	8	8	8	8
Min.starting torque (N·m)	Max.continuous differential pressure	145	215	283	359	460	530	554	734	796	781
	Max.Intermittent differential pressure	188	281	371	440	557	633	697	858	925	925
Weight(Standard/Wheeled) (kg)		11.7	11.9	12.1	12.5	12.9	13.3	13.5	14.2	15	15

T-0124

- Intermittent working condition: The working time should be less than 6 seconds per minute under the intermittent working condition.
- Peak differential pressure: At peak differential pressure, the operating time is less than 0.6 seconds per minute.
- It is not recommended for the motor to work at simultaneous maximum torque and maximum speed.
- The filtration standard of ISO 4406 cleaning standard 20/18/15 is recommended.
- High quality anti-wear hydraulic fluids are recommended.
- When the temperature is 50°, the minimum viscosity of the oil is recommended to be 20mm²/s.
- The recommended maximum operating temperature is 82°C .
- To assure best motor life, run motor 10-15 minutes in low speed high torque mode at approximately 50% of continuous pressure and 50% of continuous flow.

Ordering information

HSP	080	A3	1	S3	A	N	A
①	②	③	④	⑤	⑥	⑦	⑧

Orbital Hydraulic Series

①	Orbital Hydraulic Motor	HSP
---	-------------------------	-----

Type

②	Type	080	100	125	160	200	230	250	315	400	500
---	------	-----	-----	-----	-----	-----	-----	-----	-----	-----	-----

Mount

③	SAE Type A 2×Ø13.5 mount Ø106.4, pilot Ø82.5×6.1	A3
	SAE Type A 4×Ø13.5 mount Ø106.4, pilot Ø82.5×6.1	A2
	4×M12×1 Square mount Ø82.55, pilot Ø44.4×3	F6
	6×Ø13.5 Magneto mount Ø106.4, pilot Ø82.5×2.6	M0
	Wheeled 4×Ø13.5 mount Ø147.6, pilot Ø107.9×6.4	W1
	Wheeled 4×Ø13.5 mount Ø147.6, pilot Ø107.9×6.4, rotate 45°C	W4

Port

④	Port G1/2, drain port G1/4	1
	Port 7/8-14UNF, drain port 7/16-20UNF	2
	Port M22×1.5, drain port M14×1.5	4
	Port G1/2, drain port G1/4, flat seal	H
	Port M22×1.5, drain port M14×1.5, O-ring seal	3
	Port 1 1/16-12UNF, drain port 7/16-20UNF, O-ring seal, side oil port	6
	Rear port, port 7/8-14UNF, drain port 7/16-20UNF	D
	Port 7/8-14UNF, drain port 7/16-20UNF, rear speed sensor	N
	Port glossy hole Ø12.7, drain port G1/4(ED-ring seal), with threaded 2×M10, interchangeable oil port positions	Q

Output Shaft

⑤	Ø32 straight, parallel key 10×8×45	S3
	Ø25.4 shaft, spline SAE 6B	R1
	Ø31.75 spline 14-DP12/24	R5
	Ø25.4 straight, parallel key 6.35×6.35×31.75, center hole 1/4-20UNC	S1
	Ø31.75 straight, parallel key 7.96×7.96×31.75, center hole 3/8-16UNC	S5
	Ø31.75 spline 14-DP12/24, center hole 3/8-16UNC, with retracting groove	RA
	Ø30 6B spline, lengthening	RN
	Ø31.75 tapered shaft, parallel key 7.96×7×22.6(keyed parallel to tapered shaft)	TN
	Ø31.75 tapered shaft, parallel key 7.96×7.96×31.75(keyed parallel to tapered shaft)	T4

Ordering information

Rotation Direction

⑥	CW	A
	CCW	R

Paint Option

⑦	No Paint	N
	Black	B
	Hengli blue	C

Special Features

		F6/M0/W1	A2/A3/W4	Code
⑧	Standard	●	●	A
	Free running	●	●	F
	High temperature	●	●	V
	Low temperature	●	●	S
	High pressure shaft seal	○	●	C
	High pressure shaft seal + Dust cover	○	●	DC
	Mount rotation 90°	●	●	R
	Speed sensor, DT04-4P connector	●	●	S2

T - 0135

Note: ● =Available; ○ =Available on request; When using the order information, the user can select the motor series, displacement, installation flange, port, shaft and other information. If the selected specification is not in the table or has special requirements, please contact us.

Displacement performance

		Pressure(bar)						Max.Cont		Max.Inter	
		30	70	105	140	175	210	225	250	275	
80		80cm ³ /rev.									
		Torque(N·m), Speed(rpm)									
Flow (L/min)	5	26	59	92	117	147					
		60	57	54	52	51					
	10	33	72	110	146	183	218	233	254		
		121	118	115	111	105	98	93	86		
	20	33	74	116	155	195	236	259	278	304	
		243	239	235	231	225	217	204	203	186	
	30	29	76	118	159	199	241	268	287	316	
		367	362	357	352	345	335	330	319	303	
	40	25	72	113	154	195	235	262	280	311	
		489	483	479	473	465	455	434	438	421	
Max.Cont	50		67	108	150	190	232	260			
			608	602	595	586	574	550			
	65		66	105	146	189	230	259			
			773	766	758	747	733	696			
Max.Inter	80		62	102	143	185					
			982	974	964	953					

Overall Efficiency: 70-100% 40-69% 0-39%

T-0125

		Pressure(bar)						Max.Cont		Max.Inter	
		35	70	105	140	175	210	225	250	275	
100		100cm ³ /rev.									
		Torque(N·m), Speed(rpm)									
Flow (L/min)	5	36	80	121	159	197	232	257			
		48	47	46	44	42	38	34			
	10	37	82	125	166	227	257	276	306	337	
		97	95	93	91	85	84	82	74	69	
	20	39	90	139	187	235	280	299	326	352	
		196	194	191	189	185	180	176	168	157	
	30	41	93	143	193	244	292	316	352	383	
		295	292	288	284	280	276	269	260	249	
	40	41	92	143	193	245	297	320	356	390	
		393	390	386	382	376	369	366	355	342	
Max.Cont	50	37	88	140	192	241	293	316			
		494	488	485	481	474	466	463			
	60	33	80	133	185	235	288	310			
		592	588	584	577	571	562	556			
Max.Inter	75	30	78	130	180	230	283	304			
		739	731	725	719	709	697	690			
	90		71	123	172	223					
			892	885	876	867					

Overall Efficiency: 70-100% 40-69% 0-39%

T-0126

Displacement performance

125		Pressure(bar)						Max.Cont		Max.Inter	
		35	70	105	140	175	210	225	250	275	
125cm ³ /rev.		Torque(N·m), Speed(rpm)									
Flow (L/min)	5	51 39	109 38	166 38	226 36	281 35	333 34				
	10	57 78	120 77	182 76	244 74	301 73	353 69	373 67	405 62		
	20	54 158	119 156	179 155	244 153	306 150	367 145	395 143	437 135	473 123	
	30	50 237	115 235	177 234	243 231	306 214	370 209	396 206	441 198	483 189	
	40	44 318	109 315	174 313	238 310	303 305	367 299	395 296	441 288	485 277	
	50	41 394	106 396	170 392	234 389	298 384	364 377	392 373			
	60	38 480	96 476	168 472	232 468	297 463	363 454	390 452			
	Max.Cont	75	29 592	96 592	161 588	227 583	291 578	355 570	383 564		
	Max.Inter	90		91 714	156 709	221 703	286 694				

Overall Efficiency: 70-100% 40-69% 0-39%

T-0127

160		Pressure(bar)						Max.Cont		Max.Inter	
		35	70	105	140	160	175	210	225	260	
159cm ³ /rev.		Torque(N·m), Speed(rpm)									
Flow (L/min)	5	63 31	131 29	200 28	291 28	332 28	358 27				
	10	70 61	151 60	229 59	306 58	343 56	368 57	437 56	466 54		
	20	67 123	145 122	226 120	308 119	355 118	388 117	467 113	498 109		
	30	65 185	147 184	229 182	311 180	357 179	391 178	473 173	506 171	580 169	
	40	61 247	143 245	224 243	306 241	353 240	386 238	467 233	501 229	579 219	
	50	52 310	136 307	218 305	298 302	345 301	379 299	461 293	496 289		
	60	46 373	127 370	208 367	289 347	335 361	369 359	450 353	486 347		
	Max.Cont	75	39 465	113 458	193 455	275 451	321 448	356 446	439 438	473 433	
	Max.Inter	90	26 560	103 562	183 558	265 552	312 549				

Overall Efficiency: 70-100% 40-69% 0-39%

T-0128

Displacement performance

		Pressure(bar)							Max.Cont	Max.Inter
		35	70	105	140	160	175	210	225	260
200										
199cm ³ /rev.		Torque(N·m), Speed(rpm)								
Flow (L/min)	5	71 24	163 24	257 23	368 23					
	10	78 49	178 49	276 48	371 47	432 47	469 46	573 43		
	20	85 98	188 96	291 95	396 93	459 90	501 89	604 82	646 76	
	30	88 147	192 146	297 144	401 142	462 140	505 139	610 133	656 129	
	40	75 197	181 194	285 192	390 190	451 188	494 187	600 181	644 176	
	50	65 246	170 244	273 242	379 240	438 238	484 236	588 230	633 226	
	60	53 297	159 294	262 291	368 289	426 287	472 285	576 279	622 276	
	Max.Cont	75	44 372	150 369	254 366	359 363	420 361	464 359	569 353	612 349
	Max.Inter	90		138 447	254 442	343 438	401 435			

T-0129

Overall Efficiency: 70-100% 40-69% 0-39%

		Pressure(bar)							Max.Cont	Max.Inter
		35	70	95	125	140	155	175	200	225
230										
232cm ³ /rev.		Torque(N·m), Speed(rpm)								
Flow (L/min)	5	88 21	187 20	258 18						
	10	101 42	215 41	303 40	397 38	441 37	491 35			
	20	102 84	219 82	305 80	407 79	450 79	509 77	577 76	658 74	
	30	104 127	225 125	334 119	415 123	459 122	519 121	588 120	675 118	
	40	102 169	226 167	333 159	413 165	459 165	518 164	588 162	648 160	
	50	100 212	217 211	324 200	408 208	451 207	512 206	581 205		
	60	85 255	205 253	310 241	395 251	439 250	499 248	568 247		
	Max.Cont	75	76 256	197 318	300 302	387 315	430 314	488 312	498 310	
	Max.Inter	90		185 385	289 365	391 364	425 372			

T-0130

Overall Efficiency: 70-100% 40-69% 0-39%

Displacement performance

		Pressure(bar)								Max.Cont	Max.Inter
		35	70	95	125	140	155	175	200	225	250
250		249cm ³ /rev.									
		Torque(N·m), Speed(rpm)									
Flow (L/min)	5	87									
		20									
	10	101	208	288	364	421	506				
		39	37	36	33	30	28				
	20	103	229	315	417	463	513				
		78	76	74	73	72	70				
	30	95	223	313	421	473	538	603	675	749	855
		118	116	115	113	112	111	108	91	85	70
	40	83	213	304	414	467	538	608	676	760	
		157	155	154	152	151	149	147	142	135	
50	68	199	290	401	460	541	613				
	197	195	194	192	191	189	187				
60	51	180	273	384	439	529	600				
	238	235	234	232	230	229	226				
Max.Cont	75	21	150	241	353	408	519				
	298	296	294	295	290	288					
Max.Inter	90		110	203	321	369					
		359	356	358	350						

T-0131

Overall Efficiency: 70-100% 40-69% 0-39%

		Pressure(bar)								Max.Cont	Max.Inter
		35	70	100	120	140	160	175	200	225	250
315		314cm ³ /rev.									
		Torque(N·m), Speed(rpm)									
Flow (L/min)	5	127	254	339							
		15	14	14							
	10	133	272	393	465	547	609				
		31	30	28	26	24	22				
	20	141	305	441	528	613	669				
		62	61	59	58	55	50				
	30	144	310	453	545	635	721	783	874	969	987
		93	92	91	89	87	81	74	66	53	50
	40	134	297	440	535	627	719	785	873	949	
		125	123	122	121	119	116	113	102	95	
50	129	291	434	529	623	717	784				
	156	155	153	152	151	148	145				
60	108	272	414	509	604	697	767				
	188	186	185	184	182	180	177				
Max.Cont	75	85	254	395	490	585	679				
	236	234	232	231	229	226					
Max.Inter	90	60	228	370	464	559					
	284	283	281	279	277						

T-0132

Overall Efficiency: 70-100% 40-69% 0-39%

Displacement performance

		Pressure(bar)						Max.Cont	Max.Inter	
		30	60	80	105	120	140	160	175	190
400		392cm ³ /rev.								
		Torque(N·m), Speed(rpm)								
Flow (L./min)	5	142 11	293 10							
	10	153 25	306 24	414 23	558 22					
	20	152 50	328 49	448 48	590 47	677 46	791 45	897 39	979 36	
	30	163 75	342 74	460 73	608 72	697 71	815 70	931 68	997 65	1056 60
	40	153 100	331 99	451 98	599 97	688 96	810 95	923 93	978 91	
	50	136 125	330 124	454 123	590 122	688 121	776 121			
	60	123 150	298 150	417 149	566 148	657 147	775 145			
	Max.Cont	75	96 188	278 188	399 187	544 185	635 185			
	Max.Inter	90	68 225	248 229	367 227	517 224				

T-0133

Overall Efficiency: 70-100% 40-69% 0-39%

		Pressure(bar)					Max.Cont	Max.Inter
		25	50	80	90	105	120	140
500		488cm ³ /rev.						
		Torque(N·m), Speed(rpm)						
Flow (L./min)	10	160 20	329 20					
	20	152 41	333 40	547 40	616 39	722 34		
	30	160 57	342 57	561 56	633 56	740 56	847 55	986 54
	40	153 81	337 81	557 80	629 80	736 79	842 79	
	50	132 102	316 101	538 100	613 100	723 100	835 99	
	60	121 122	304 122	526 121	597 121	708 121		
Max.Cont	75	92 153	260 153	478 152	552 151	664 151		
Max.Inter	90	56 177	223 186	447 184	518 184			

Torque(N·m):835
Speed(rpm): 99

Overall Efficiency: 70-100% 40-69% 0-39%

T-0134

Installation size

Port size

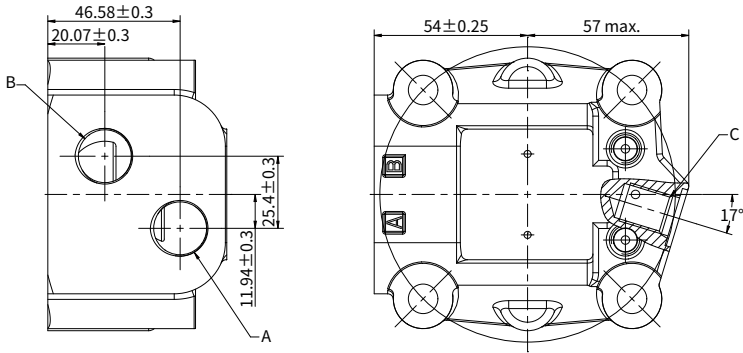

P - 0167

Code	Port A/B	Drain port C
1	G1/2	G1/4
2	7/8-14UNF	7/16-20UNF
4	M22x1.5	M14x1.5
H	G1/2	G1/4
3	M22x1.5	M14x1.5
6	1-1/16-12UNF	7/16-20UNF
N	7/8-14UNF	7/16-20UNF
Q	Ø12.7	G1/4

T - 0232

Rear Port Size

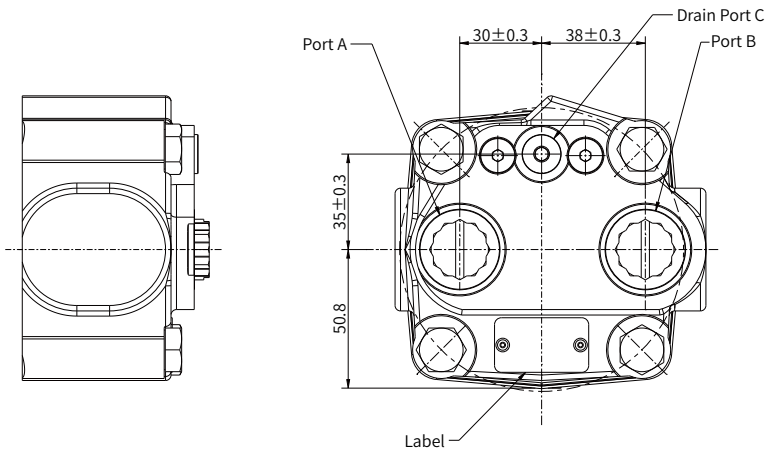

P - 0313

Code	Port A/B	Drain port C
D	7/8-14UNF	7/16-20UNF

T - 0233

Installation size

A3 2-HOLE, SAE A MOUNT

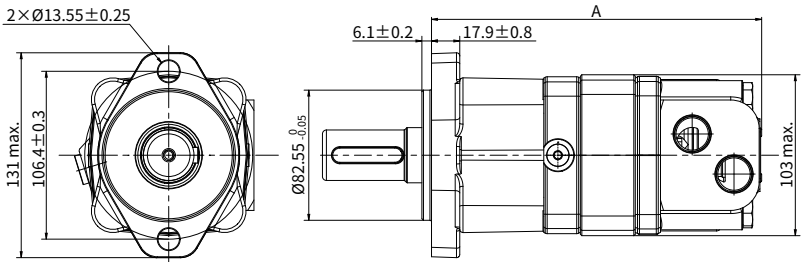

P - 0157

A2 4-HOLE, SAE A MOUNT

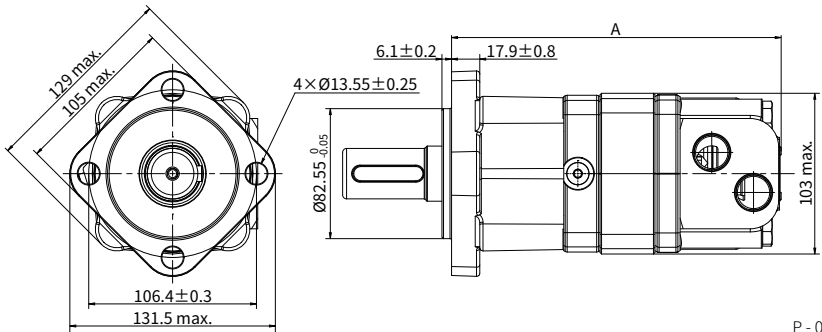

P - 0158

F6 FOUR-THREADED HOLE SQUARE FLANGE

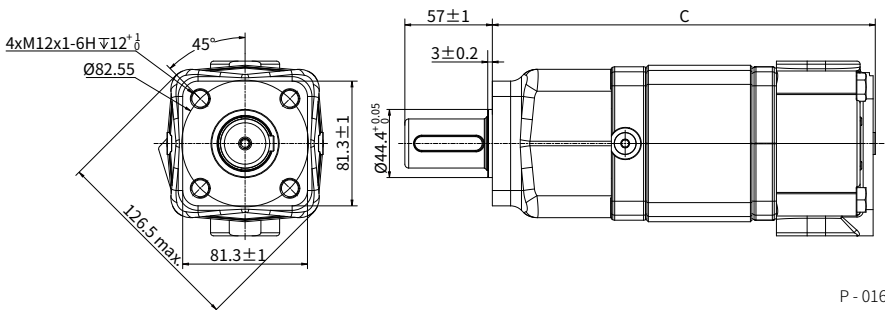

P - 0161

Length and weight

Type	A mm	B mm	C mm
80	188.0	192.1	194.7
100	191.4	195.5	198.1
125	195.8	199.9	202.5
160	201.8	205.9	208.5
200	208.8	212.9	215.5
230	214.5	218.6	221.2
250	217.5	221.6	224.2
315	228.8	232.9	235.5
400	242.4	246.5	249.1
500	242.4	246.5	249.1

T-0136

Note: Dimensions A, B, C are the length from the flange mounting surface to the rear end of the motor, and the tolerance is $\pm 0.61\text{mm}$.

Speed sensor

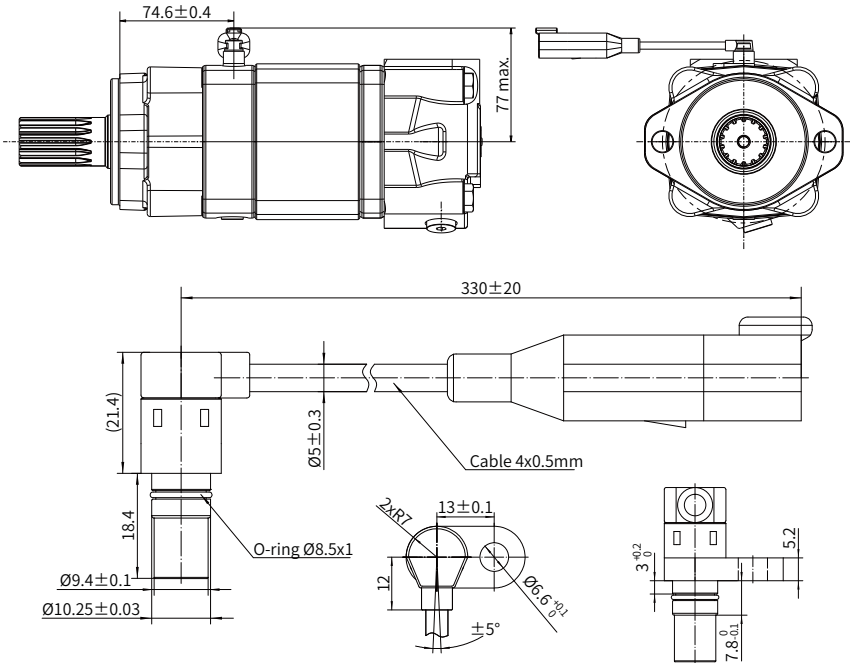

P - 0305

Speed sensor

Dimensions	Ø10.25 /L=18.4mm
Voltage	5-26VDC
Input Current	<15mA
Sensing distance	0.2~1.7mm
Power reverse protection (Y/N)	Yes
Power input overcurrent and overvoltage protection (Y/N)	Yes
Maximum output current	40mA
Voltage drop	≤ 2VDC
Working frequency	0-20KHz
Output signal	A, B
Operating temperature	-40°C ~ +125°C
Protection	IP69K
Shell material	Stainless steel/plastic
Pressure resistance of measuring surface	500bar
Connector	Cable 0.33m, Injection 4-core DEUTSCH DT04-4P-EP04 plug

T - 0236

■ WIRING DIAGRAM

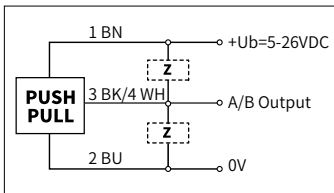

P - 0306

■ TERMINAL ASSIGNMENT

Signal		+Ub	0V	A	B
Color		BN	BU	BK	WH
4 core plug DT04		1	2	3	4

P - 0307

Shaft end dimensions

S3

Ø32mm Straight
 Parallel key: 10×8×45
 Max. Torque: 881N·m

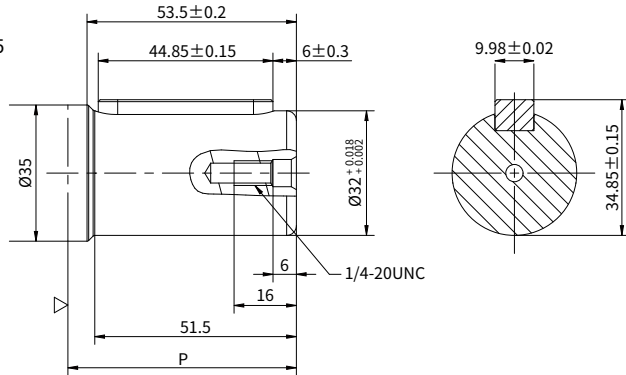

P-0163

R1

Ø25.4mm Straight
 Spline: SAE 6B (B.S.2059)
 Max. Torque: 678N·m

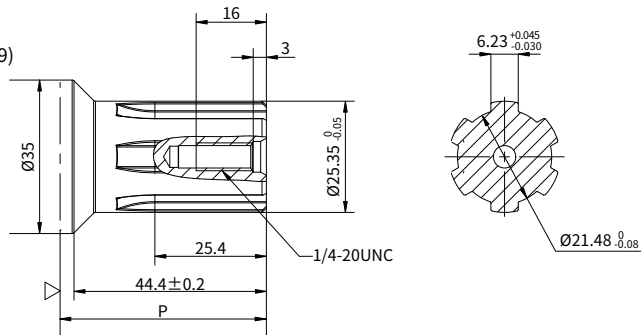

P-0166

R5

Ø31.75mm
 Spline: 14-DP12/24, ANS B92.1 - 1996
 Max. Torque: 881N·m

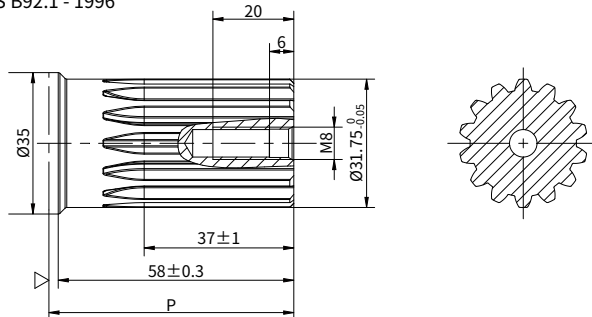

P-0165

Shaft end dimensions

S1

Ø25.4mm Straight
 Parallel key: 6.35 × 6.35 × 31.75
 Max. Torque: 678N · m

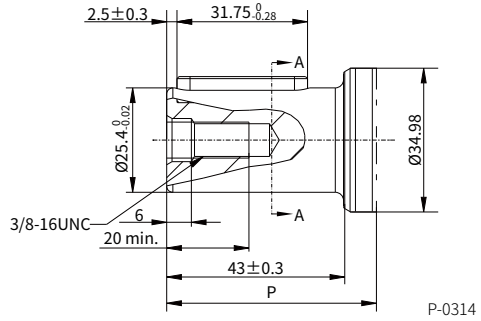
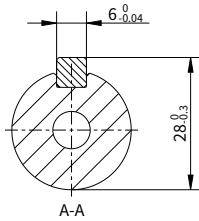

S5

Ø31.75mm Straight
 Parallel key: 7.96 × 7.96 × 31.75
 Max. Torque: 881N · m

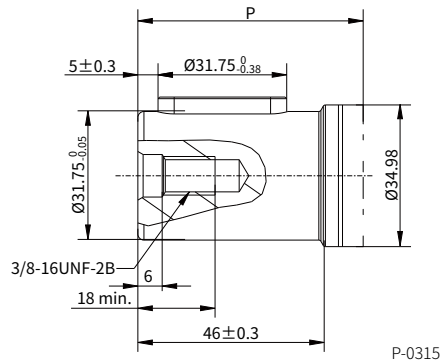
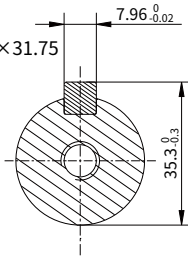

RN

Ø30mm shaft
 Spline: SAE 6B
 Max. Torque: 768N · m

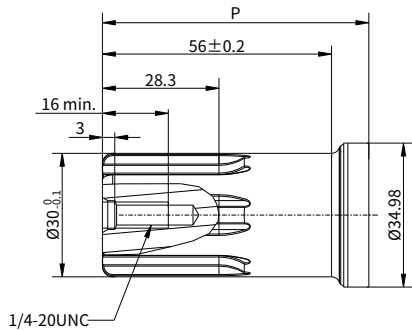
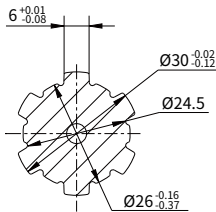

P-0316

Shaft end dimensions

RA

Ø31.75mm Shaft
 Spline: 14-DP12/24, ANSI B92.1 - 1996
 Max. Torque: 881N · m

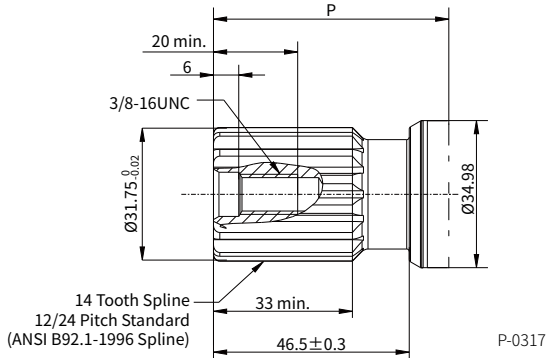

TN

Ø31.75mm Tapered shaft
 Parallel key: 7.96×7×22.6
 Tightening torque: 200±10N · m
 Max. Torque: 881N · m

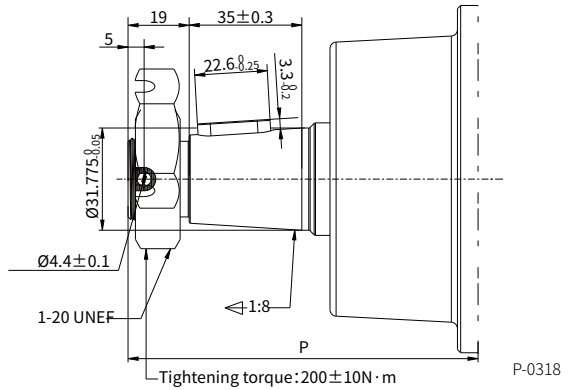
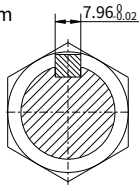

T4

Ø31.75mm Tapered shaft
 Parallel key: 7.96×7.96×31.75
 Tightening torque: 200±10N · m
 Max. Torque: 881N · m

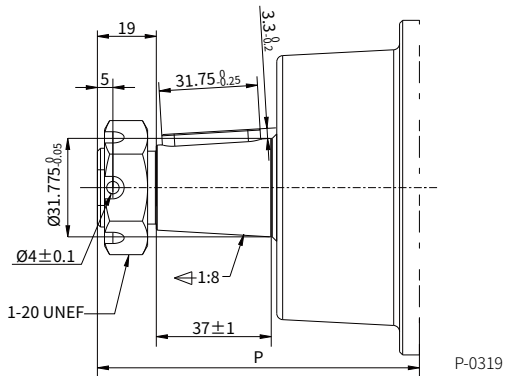
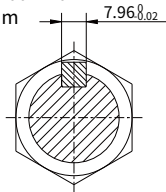

Shaft end dimensions

P mm	SAE Mount	Magneto Mount	Square Mount	Wheeled Mount
S3	69.2	63.8	57.1	-
R1	55.0	49.6	42.9	-
R5	66.0	60.6	53.9	-
S1	51	45.6	38.9	-
S5	55.6	50.2	43.5	-
RN	76.8	71.4	64.7	-
RA	68.0	62.6	55.9	-
TN	-	-	-	108.8
T4	-	-	-	104

T-0137

Note: Dimension P is the overall distance from the flange mounting surface to the end of the shaft, and the tolerance is $\pm 0.97\text{mm}$.

Allowable shaft load/bearing curve

As shown in the figure, when the axial load is 0, the radial allowable load of the output shaft is related to the distance from the flange mounting surface to the load action point.

The solid line shows the allowable radial load of the bearing. It is based on L_{10} bearing life 2000 hrs at 100 RPM with rated output torque.

Any shaft load exceeding the values quoted in the curve will involve a risk of failure.

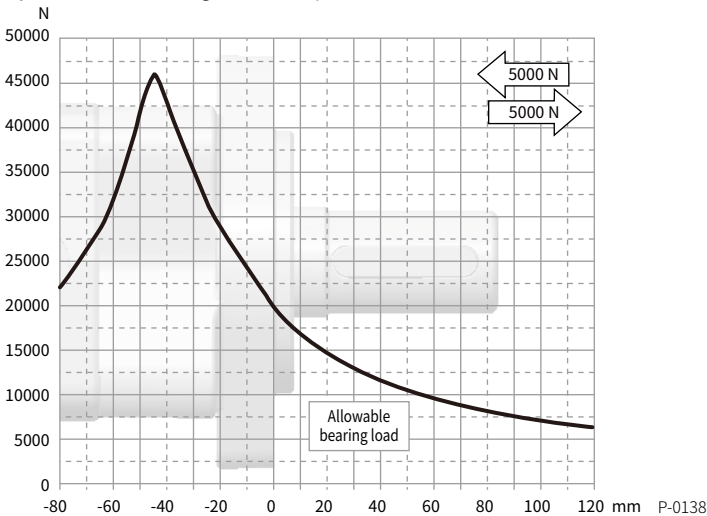

Standard shaft seal pressure

When case drain port is not working, the pressure on the output shaft seal is slightly higher than the pressure in the return line.

When using a drain line, the pressure on the shaft seal of the output shaft is the same as the pressure in the drain line.

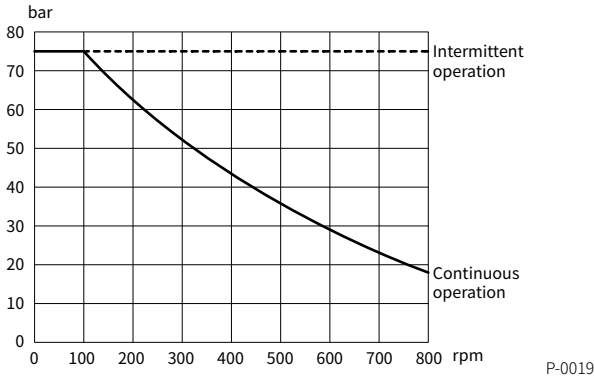

P-0019

Rotation direction: CW

When facing the motor shaft extension direction, port A is high pressure oil, the output shaft rotates CW; Otherwise, it rotates CCW.

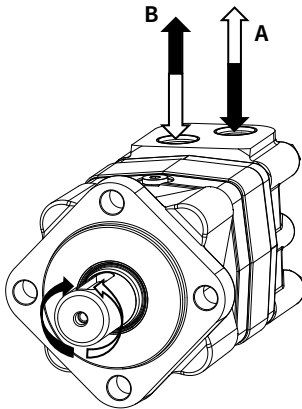

P-0028

Hydraulic diagram

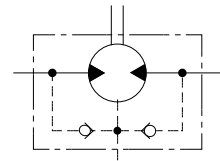

P-0020

